

VIKING

TECHNICAL Practice

TELECOM SOLUTIONS FOR THE 21ST CENTURY

E-1600A-BLT-EWP

**ADA Compliant
Emergency Tower
Phone with Strobe**

April 18, 2006



ADA Compliant Emergency Tower Phone with Blue Strobe Light and Voice Announcer

Many new building codes require emergency communication in elevators and "Area of Refuge" sites. Now you can provide added safety for your patrons, employees, and students with the addition of High Visibility, ADA Compliant emergency communication. At the simple push of a button, the **E-1600A-BLT-EWP** will initiate a call to your emergency personnel and send a digital announcement to identify the location of the emergency call. In addition, the tower phone's bright (1million candle power) strobe light will instantly begin flashing to deter further activity and make it fast and easy for Police or Security personnel to locate the site of the emergency.

Though the strobe requires external power to operate, rest assured that communication is possible, even during power failures! All phone numbers, location numbers and programming parameters are stored in non-volatile memory. No batteries are required to hold the memory.

The **E-1600A-BLT-EWP** is equipped for outdoor or harsh environments with Enhanced Weather Protection (**EWP**). EWP features rubber gaskets and boots, hand soldered silicon sealed connections, gel filled butt connectors, as well as urethane potted circuit boards with internally sealed, field-adjustable trim pots and DIP switches for easy on-site programming.

Phone...715.386.8861

Features

- **Enhanced Weather Protection (EWP)**  *Need More Information on EWP? Call (715) 386-4345 and select 859.*
- Meets ADA requirements for Emergency Phones:
 - Can automatically light the "Call Connected" LED for the hearing impaired
 - Transmits a unique location I.D. code or voice announcement
 - Grade 2 Braille label for the visually impaired
- **Non-volatile digital voice announcer with 16 seconds of voice memory**
- 1 million candle power blue strobe light
- **Advanced call progress detection**
- Handsfree operation
- Phone line powered emergency phone (strobe requires power)
- Non-volatile memory (no batteries required)
- Touch Tone or pulse dialing
- **Dials up to 5 emergency numbers**
- **Cycles through backup emergency and non-emergency numbers on busy or no-answer**
- Hangs up on CPC, silence, busy signal, dial tone, time-out or Touch Tone command
- Programmable to auto-answer on incoming calls
- Remotely programmable
- Extended temperature range (-15°F to 130°F)
- Central Station Monitoring capability (dials 2 numbers)
- **Separate central station voice speed dial number**
- **Optional PB-100 Polling System available (see page 10)**
- High visibility, vandal and weather resistant
- Vandal resistant polycarbonate strobe lens
- Surface mountable

Applications

- Campus Security Sites
- Area of Refuge sites
- Parking Ramps/Lots
- Automated Tellers (ATM)
- Entryways
- Roadside Emergency Sites
- Stairwells in Public Buildings

CAUTION - When installing on an analog extension of a phone system: Some phone systems do not conform to analog telecom standards and might not be compatible with the 1600A Series emergency phones. For a detailed description of the telephone line specifications required for any of the 1600A Series phones, retrieve Fax Back Document 869.

Specifications

Phone Power: Telephone line powered. Minimum 24V DC talk battery voltage, with a minimum loop current of 20mA loop (room temp), or 25mA (extended cold temp range). Loop current may be boosted on low current lines with a Viking Model TBB-1 talk battery booster (**Fax Back # 630**).

Strobe Power: 120V AC/12V DC power adapter (included)

Maximum Strobe Power Run: 200 feet using 24 awg wire

Dimensions: 1070mm x 152.4mm x 109.3mm (42" x 6" x 4.5")

Shipping Weight: 5.9 kg (13 lbs)

Mounting: Surface mount to rigid wall or post

Environmental: -26°C to 54°C (-15°F to 130°F) with 5% to 95% non-condensing humidity

Strobe Output: 1,000,000 candle power

Material: Enclosure - .125 aluminum, 76.2mm x 152.4mm (3" x 6") tube, powder painted high-visible yellow, Phone - .074 (14 gauge) stainless steel with stainless steel button, Strobe - Vandal resistant polycarbonate plastic

Connections: Color-coded wires with gel-filled butt connectors

IF YOU HAVE A PROBLEM WITH A VIKING PRODUCT, PLEASE CONTACT: VIKING TECHNICAL SUPPORT AT (715) 386-8666

Our Technical Support Department is available for assistance weekdays between 8 a.m. and 5 p.m. central time. So that we can give you better service, before you call please:

1. Know the model number, the serial number and what software version you have (see serial label).
2. Have your Technical Practice in front of you.
3. It is best if you are on site.

RETURNING PRODUCT FOR REPAIR

The following procedure is for equipment that needs repair:

1. Customer must contact Viking's Technical Support Department at 715-386-8666 to obtain a Return Authorization (RA) number. The customer MUST have a complete description of the problem, with all pertinent information regarding the defect, such as options set, conditions, symptoms, methods to duplicate problem, frequency of failure, etc.
2. Packing: Return equipment in original box or in proper packing so that damage will not occur while in transit. Static sensitive equipment such as a circuit board should be in an anti-static bag, sandwiched between foam and individually boxed. All equipment should be wrapped to avoid packing material lodging in or sticking to the equipment. Include ALL parts of the equipment. C.O.D. or freight collect shipments cannot be accepted. Ship cartons prepaid to:
Viking Electronics, 1531 Industrial Street, Hudson, WI 54016
3. Return shipping address: Be sure to include your return shipping address inside the box. We cannot ship to a PO Box.
4. RA number on carton: In large printing, write the R.A. number on the outside of each carton being returned.

RETURNING PRODUCT FOR EXCHANGE

The following procedure is for equipment that has failed out-of-box (within 10 days of purchase):

1. Customer must contact Viking's Technical Support at 715-386-8666 to determine possible causes for the problem. The customer MUST be able to step through recommended tests for diagnosis.
2. If the Technical Support Product Specialist determines that the equipment is defective based on the customer's input and troubleshooting, a Return Authorization (R.A.) number will be issued. This number is valid for fourteen (14) calendar days from the date of issue.
3. After obtaining the R.A. number, return the approved equipment to your distributor, referencing the R.A. number. Your distributor will then replace the product over the counter at no charge. The distributor will then return the product to Viking using the same R.A. number.
4. **The distributor will NOT exchange this product without first obtaining the R.A. number from you. If you haven't followed the steps listed in 1, 2 and 3, be aware that you will have to pay a restocking charge.**

WARRANTY

Viking warrants its products to be free from defects in the workmanship or materials, under normal use and service, for a period of one year from the date of purchase from any authorized Viking distributor or 18 months from the date manufactured, which ever is greater. If at any time during the warranty period, the product is deemed defective or malfunctions, return the product to Viking Electronics, Inc., 1531 Industrial Street, Hudson, WI, 54016. Customer must contact Viking's Technical Support Department at 715-386-8666 to obtain a Return Authorization (R.A.) number.

This warranty does not cover any damage to the product due to lightning, over voltage, under voltage, accident, misuse, abuse, negligence or any damage caused by use of the product by the purchaser or others.

Viking's sole responsibility shall be to repair or replace (at Viking's option) the material within the terms stated above. VIKING SHALL NOT BE LIABLE FOR ANY LOSS OR DAMAGE OF ANY KIND INCLUDING INCIDENTAL OR CONSEQUENTIAL DAMAGES RESULTING DIRECTLY OR INDIRECTLY FROM ANY BREACH OF ANY WARRANTY EXPRESSED OR IMPLIED, OR FOR ANY OTHER FAILURE OF THIS PRODUCT. Some states do not allow the exclusion or limitation of incidental or consequential damages, so this limitation may not apply to you.

THIS WARRANTY IS IN LIEU OF ALL OTHER WARRANTIES, EXPRESSED OR IMPLIED, INCLUDING THE WARRANTIES OF MERCHANTABILITY AND FITNESS FOR A PARTICULAR PURPOSE, WHICH ARE HEREBY EXCLUDED BEYOND THE ONE YEAR DURATION OF THIS WARRANTY. Some states do not allow limitation on how long an implied warranty lasts, so the above limitation may not apply to you.

FCC REQUIREMENTS

This equipment complies with Part 68 of the FCC rules. Located on the equipment is a label that contains, among other information, the FCC registration number and ringer equivalence number (REN). If requested, this information must be provided to the telephone company.

The REN is used to determine the quantity of devices which may be connected to the telephone line. Excessive REN's on the telephone line may result in the devices not ringing in response to an incoming call. In most, but not all areas, the sum of the REN's should not exceed five (5.0). To be certain of the number of devices that may be connected to the line, as determined by the total REN's, contact the telephone company to determine the maximum REN for the calling area.

This equipment cannot be used on the telephone company-provided coin service. Connection to Party Line Service is subject to State Tariffs.

If this equipment causes harm to the telephone network, the telephone company will notify you in advance that temporary discontinuance of service may be required. If advance notice isn't practical, the telephone company will notify the customer as soon as possible. Also, you will be advised of your right to file a complaint with the FCC if you believe it is necessary.

The telephone company may make changes in its facilities, equipment, operations, or procedures that could affect the operation of the equipment. If this happens, the telephone company will provide advance notice in order for you to make the necessary modifications in order to maintain uninterrupted service.

If trouble is experienced with this equipment, please contact: **Viking Electronics, Inc., 1531 Industrial Street, Hudson, WI 54016 (715) 386-8666**

If the trouble is causing harm to the telephone network, the telephone company may request you to remove the equipment from the network until the problem is resolved.

until the problem is resolved.

The E-1600A-BLT-EWP uses the USOC jack RJ11C.

It is recommended that the customer install an AC surge arrester in the AC outlet to which this device is connected. This is to avoid damaging the equipment caused by local lightning strikes and other electrical surges.

This equipment is Hearing-Aid Compatible (HAC).

The telephone Consumer Protection Act of 1991 makes it unlawful for any person to use a computer or other electronic device, including fax machines, to send any message unless such message clearly contains in a margin at the top or bottom of each transmitted page or on the first page of the transmission, the date and time it is sent and an identification of the business or other entity, or other individual sending the message and the telephone number of the sending machine or such business, other entity, or individual. (The telephone number provided may not be a 900 number or any other number for which charges exceed local or long-distance transmission charges.)

PART 15 LIMITATIONS

This equipment has been tested and found to comply with the limits for a Class A digital device, pursuant to Part 15 of the FCC Rules. These limits are designed to provide reasonable protection against harmful interference when the equipment is operated in a commercial environment. This equipment generates, uses, and can radiate radio frequency energy and, if not installed and used in accordance with the instruction manual, may cause harmful interference to radio communications. Operation of this equipment in a residential area is likely to cause harmful interference in which case the user will be required to correct the interference at his own expense.

Installation

A. Wiring

Preparing the Power Supply

Step 1. Cut off the barrel connector.

Step 2. Separate the wires.

Step 3. Connect 12V adapter wires to power supply wires on the LDB-3 Control Module using the supplied butt connectors and then plug in power supply.

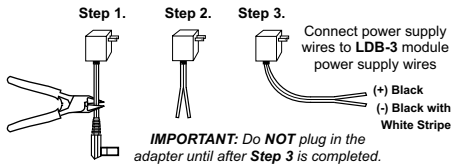

Rear View of the E-1600A-BLT-EWP Phone Panel

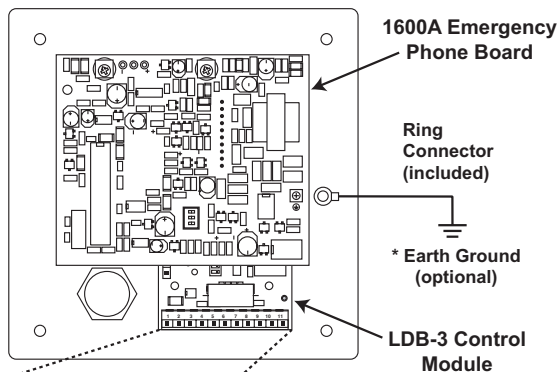

*** Note:** To increase surge protection, loosen the PCB mounting screw labeled ⊕ (as shown) and fasten a wire with ring connector (included) from the mounting screw to Earth Ground (grounding rod, water pipe, etc.)

**** Note:** The gel-filled (water tight) butt connectors are designed for insulation displacement. Do not strip wires prior to terminating.

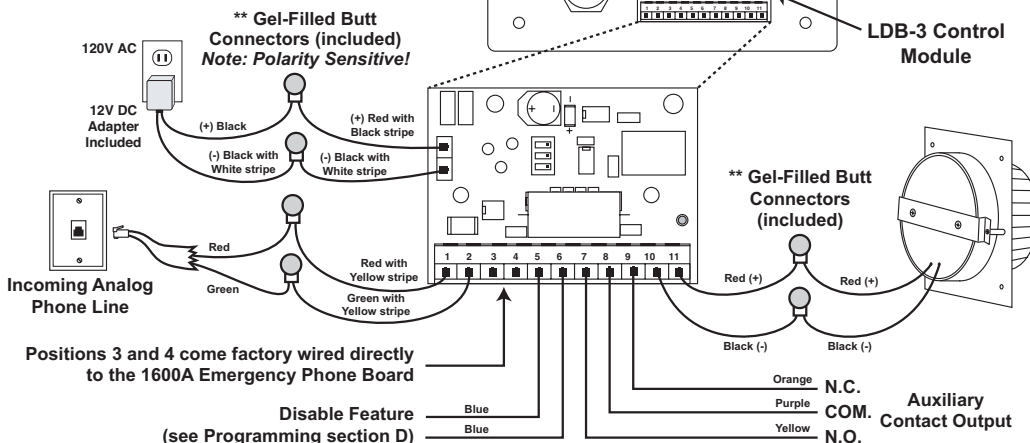

Rear View of the Strobe Light Panel (included)

! IMPORTANT: Electronic devices are susceptible to lightning and power station electrical surges from both the AC outlet and the telephone line. It is recommended that a surge protector be installed to protect against such surges. Contact Panamax at (800) 472-5555 or Electronic Specialists Inc. at (800) 225-4876.

B. Mounting

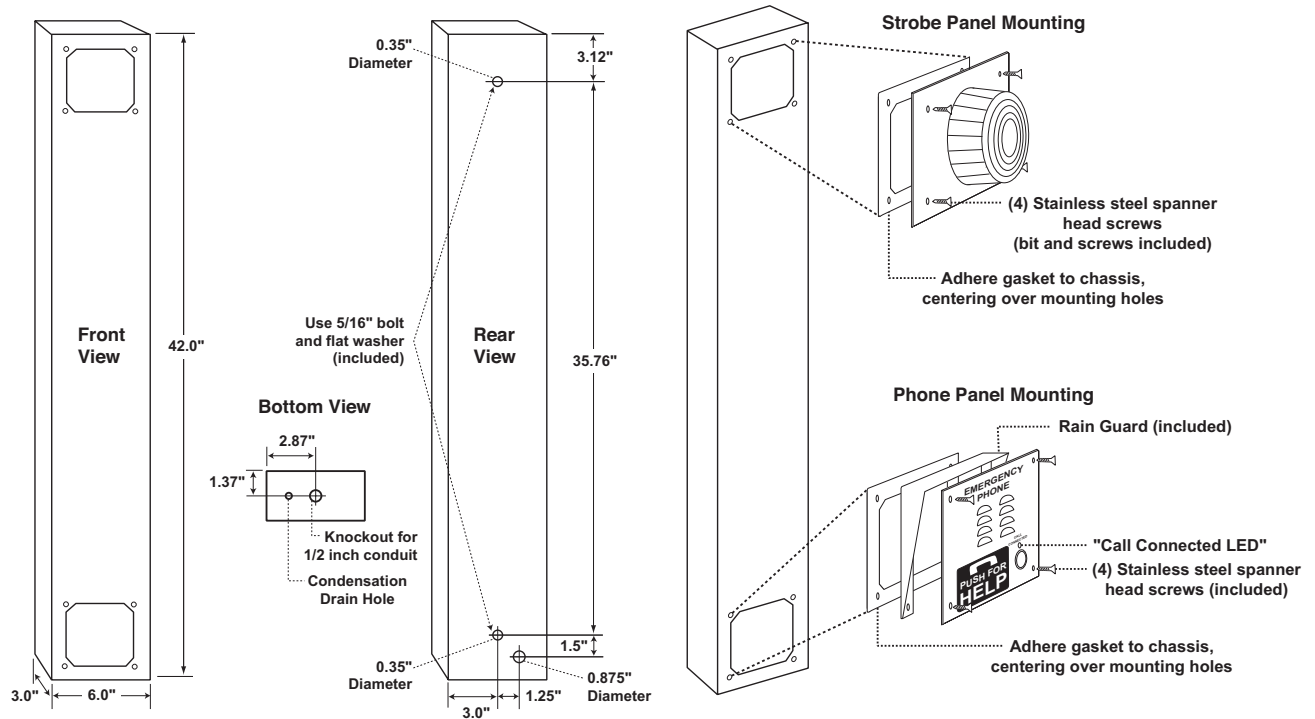

Step 1.	Mount the tower phone approximately 42" above the floor to a flat, sturdy surface using 5/16 hardware. Note: Flat washers should be used on the main mounting bolts for additional strength.
Step 2.	Locate the strobe light panel and pass the red and black wires from the strobe panel through the gasket and the upper hole in the tower.
Step 3.	Mount the strobe panel to the tower using the four security screws provided.
Step 4.	Locate the phone panel. Using the gel-filled butt connectors, connect the red and black wires labeled "Strobe Light" to the red and black wires on the strobe panel.
Step 5.	Connect the phone line to the red and green wires (this connection is not polarity sensitive).
Step 6.	Connect the 12V DC adapter wires black (+) and black with white stripe (-) to the red with black stripe and black with white stripe wires from the LDB-3 control module.
Step 7.	Mount the phone panel to the tower using the remaining four security screws.

LDB-3 Control Module Programming

A. DIP Switches

Sw 1	Sw 3	Description
ON	OFF	Ring Indication Only.
OFF	ON	Off-Hook/Loop Current Detection Only.
ON	ON	Ring and Off-Hook/Loop Current Detection.
Sw 2	Ring Cadence Mode (see section B)	
ON	Ring Cadence Mode ON - strobe remains activated in between rings.	
OFF	Ring Cadence Mode OFF - strobe is activated only during ringing.	

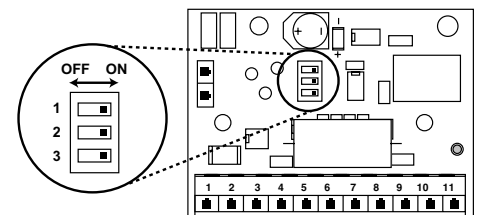

1. Ring Indication Only

Place DIP switch **2** on the **1600A** emergency phone board in the **OFF** position (not shown in the diagram - see **1600A Emergency Phone Board Programming** section J). **Note:** With DIP switch **2** in the **OFF** position, the **1600A** emergency phone board will not answer an incoming call. The **LDB-3** control module can monitor for ringing any place along the ringing line. Place DIP switch **1** **ON** and DIP switch **3** **OFF**.

2. Loop/Off-hook Indication Only

Place DIP switch **1** **OFF** and DIP switch **3** **ON**. In this configuration, the **E-1600A-BLT-EWP** will only flash the strobe light while off-hook (while the emergency phone is in use).

3. Both Ring and Loop/Off-hook Indication

If the application requires ring and loop/off-hook indication, place DIP switch **1** and **3** in the **ON** position.

B. Ring Cadence Mode

DIP switch 2 is used for switching between different ring detection modes. In the **OFF** position, the strobe light and relay will activate only while ring voltage is present and will turn off between rings. In the **ON** position, the strobe light and relay will remain on for up to 5.75 seconds after the ringing has stopped. This allows the strobe light and relay to remain on between rings of a standard ring cadence. **Note:** *To use the Ring Cadence Mode, ring detection MUST be enabled (DIP switch 1 - ON).*

C. Relay Contacts

Normally open and normally closed relay contacts are available on the orange, purple and yellow wires. The contacts are rated at .5A @ 125VAC/1A @ 30VDC. If contacts are driving an inductive load, place a suppression device at the load to snub high voltage spikes.

D. Disable Feature

The “Disable” input can be connected to a switch for remotely disabling/turning off the strobe light and the device controlled by the auxiliary contacts (camera, etc.).

1600A Emergency Phone Board Programming

A. Accessing the Programming Mode

The **1600A** emergency phone board can be programmed from any Touch Tone phone using a C.O. line, analog PABX/KSU station, or a **DLE-200B** Line Simulator.



1. Using the Security Code

Step 1.	Move DIP switch 2 to the ON position (sets unit to answer incoming calls, see section J).
Step 2.	From a Touch Tone phone call the line attached to the 1600A emergency phone board.
Step 3.	When the phone board answers, enter the 6-digit security code (factory set to 845464 , see section C). A double beep should then be heard indicating you have entered the programming mode.

2. Without the Security Code

Step 1.	Move DIP switch 2 to the ON position (sets unit to answer incoming calls, see section J).
Step 2.	Move DIP switch 3 to the OFF position (incoming calls enter Programming without security code, see section J).
Step 3.	From a Touch Tone phone call the line attached to the 1600A emergency phone board.
Step 4.	When the phone board answers, a double beep will be heard and will automatically enter the programming mode.
Step 5.	When finished programming, move DIP switch 3 back to the ON position (see section J).

B. Quick Programming Features

	Enter Digits	- then -	Enter Memory Location
First emergency speed dial number	0-20 digits	then	#00
Second emergency speed dial number	0-20 digits	then	#01
Third emergency speed dial number	0-20 digits	then	#02
Fourth emergency speed dial number	0-20 digits	then	#03
Fifth emergency speed dial number	0-20 digits	then	#04
Central station receiver number	0-20 digits	then	#05
Central station voice number	0-20 digits	then	#06
Voice announcer options (factory set to 000000)	6 digits	then	#17
Timing/Dialing options (factory set to 234111)	6 digits	then	#18
Security code (factory set to 845464)	6 digits	then	#19
Identification number (factory cleared)	0-20 digits	then	#20
To add a * at any point in the dialing string	**		
To add a # at any point in the dialing string	*#		
To add a four second pause at any point in the dialing string	*7		
To switch to pulse dialing at any point in the dialing string	*6		
To clear any speed dial number	(no digits)	then	#00 - #09

Note: *A double beep indicates a valid memory position, four beeps indicate an error.*

C. Security Code (memory location #19)

The security code allows the user/installer to program the **1600A** emergency phone board while DIP switch **3** is in the **ON** (normal) position. The factory set security code is 845464 (V-I-K-I-N-G). It is recommended that the factory set security code be changed. **Example:** To store 123456 as the security code:

Step 1.	Access programming as shown in Programming section A.
Step 2.	Enter 123456 #19 ..
Step 3.	Hang-up.

Enter Your Security Code Here:

						#19
--	--	--	--	--	--	------------

Note: The security code must be 6 digits and cannot include a * or a #.

D. Speed Dial Numbers

Note: Up to 20 digits can be stored in each dial position. Special features such as pause, mode change, Touch Tone * and # count as single digits.

1. Emergency Speed Dial Numbers (memory locations #00 - #04)

The emergency speed dial number programmed in location **#00** is the number that is dialed when the "Help" button is first pressed. Additional speed dial numbers will be dialed when there is no answer or a busy signal is detected and the next number redial features are activated. To program, enter the desired speed dial number followed by the location number (**#00 - #04**). To clear a speed dial location, simply enter the memory location (**#00 - #04**) alone. The **1600A** emergency phone board is factory set with no speed dial number programmed.

To Program:	Enter:
*	**
#	*#
4 second pause	*7
switch to pulse mode	*6
0, 1, 2...9	0, 1, 2...9

2. Speed Dial Programming Examples

To Program the 1600A Emergency Phone Board...	Step 1 - See Section A	Step 2 - Enter Digits:
...to store 555-1234 as the first emergency speed dial number	Enter Programming	5 5 5 1 2 3 4 # 0 0
...to store a Touch Tone 9, a four second pause and then a pulse dialed 333-4444 into the second speed dial memory position	Enter Programming	9 *7 *6 3 3 3 4 4 4 4 # 0 1
...to clear the first emergency speed dial number	Enter Programming	# 0 0

E. Identification Number (memory location #20)

The Touch Tone I.D. number (up to 20 digits) is used by emergency personnel to identify the location of the caller and is given out when the receiving party presses a Touch Tone *. The security office can display the number using a Touch Tone decoder. To program the I.D. number, enter the desired number followed by **#20**. **Example:** To store 333 as the I.D. number, enter: **3 3 3 # 2 0**

F. Timing/Dialing Options (memory location #18)

There are six positions in the timing/dialing options. To program these options, enter the six desired timing/dialing numbers followed by **#18**. The six available timing/dialing options are defined as follows:

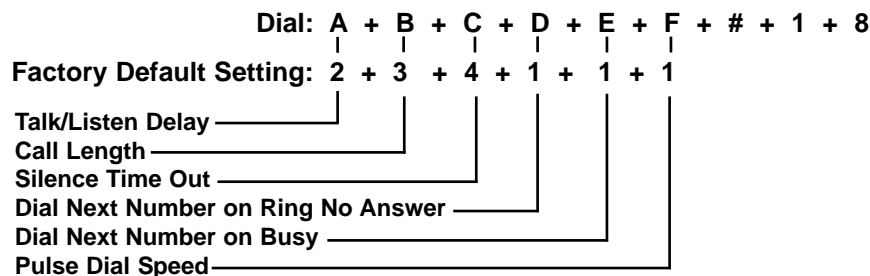

Enter Timing/Dialing Settings Here:

A	B	C	D	E	F	#18

Touch Tone	Talk/Listen Delay
1	.1 sec
2	.2 sec *
3	.3 sec
4	.4 sec
5	.5 sec
6	.6 sec
7	.7 sec
8	.8 sec
9	.9 sec

Setting A - Talk/Listen Delay

This feature selects switching time between talk and listen modes (VOX switching time). Use chart at the right. *** Note:** The factory default is .2 seconds.

Setting C - Repeat Announcement Option

The phone board can be programmed to play the announcement from 1-9 times, or to continuously repeat the announcement every 8 seconds until a Touch Tone * is detected from the distant party. The I.D. number (if programmed) will be sent and the call connected LED will turn on automatically after the announcement has stopped repeating.

Touch Tone	Setting C
0	Repeat every 8 secs*
1-9	Repeat 1-9 times

* **Note:** The factory default for the **1600A** emergency phone board is to repeat until a * is detected (digit 0).

H. Recording the Announcement

Step 1.	Call into the 1600A emergency phone board with a Touch Tone phone and access programming.
Step 2.	Enter *4, wait for the tone and then begin recording. Sixteen seconds of record time is available.
Step 3.	Enter any Touch Tone to stop the recording. Playback is automatic.
Step 4.	Enter *5 to review the announcement again.
Step 5.	If you choose to not use a voice announcement, enter *3 to clear the recording.

Example: "Elevator number 1215, located in the Financial Building, needs assistance. Press the asterisk (*) key on your telephone to start and stop this announcement..."

I. Automating the Call Connected LED

There are two methods of turning on the Call Connected LED. The LED will turn on after a Touch Tone * is detected from the distant party or after the voice announcer is finished playing a programmed number of times. If you want the Call Connected LED to light automatically when the call has been answered, but you don't want a voice announcement to be played, follow these programming steps:

Step 1:	Step 2:	Step 3:
Access Programming as shown in section A	Make a short (1 second) recording of silence	Enter digits: 001000#17

J. DIP Switch Programming/Speaker and Microphone Adjustments

Two POTs are provided to increase or decrease speaker volume and microphone sensitivity. In certain noisy locations the microphone sensitivity may need to be decreased as shown below. **Caution:** Setting the microphone gain too high may cause distorted audio, prevent the distant party from breaking over and inhibit second number redialing.

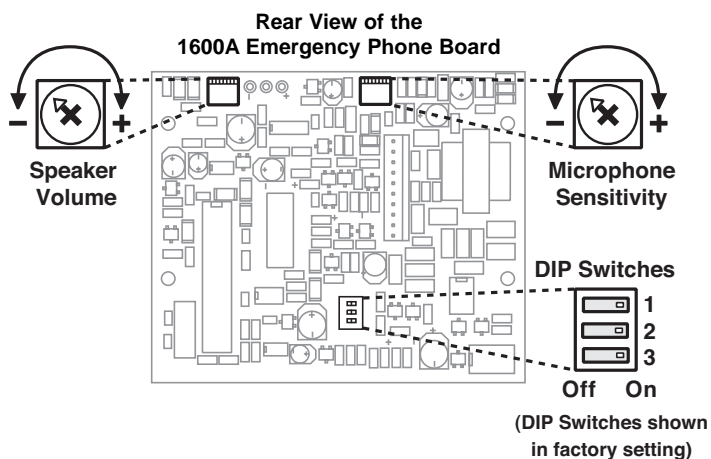

DIP Switch	Position	Description
1	ON	"Help" button alternately connects and disconnects calls (factory default)
1	OFF	"Help" button connects calls only
2	ON	Incoming calls answered (factory setting)
2	OFF	Incoming calls are not answered
3	ON	Normal operation mode (factory setting)
3	OFF	Learn mode - Any incoming calls are automatically entered into the programming mode (no security code required). Use this option if you have forgotten your security code.

K. Central Station Programming

The standard **1600A** emergency phone board is capable of communicating using the "Ademco Contact I.D.", "Ademco High Speed", "DTMF 4+1 Express", or the "DTMF 4+2 Express" formats. All formats use the programming memory location **#20** to store the account code and alarm details.

b. Ademco High Speed Format

This DTMF format consists of a four digit account code, eight zone codes and one alarm type digit. With this format you can identify up to eight different phones by using a zone per phone. A "5" in a zone position means no alarm. The following example shows an alarm from the third phone.

XXXX 55 1 55555 7 #20
Account Code | Idle Zone | Memory Location | Normal Alarm | New Event

Enter Ademco High Speed ID Settings Here: 55 1 55555 7 #20

c. 4+1 Express Format

This DTMF format consists of a four digit account code, two digit message type, and a single digit event code.

XXXX 17 X #20
Account Code | Message Type | Memory Location | Event Code

Enter 4+1 Express ID Settings Here: 17 #20

d. 4+2 Express Format

This DTMF format consists of a four digit account code, two digit message type, and a two digit event code.

XXXX 27 XX #20
Account Code | Message Type | Memory Location | Event Code

Enter 4+2 Express ID Settings Here: 27 #20

Operation

A. Standard Operation

When the "HELP" button is pressed, the **E-1600A-BLT-EWP** phone goes off-hook and dials a pre-programmed telephone number. The Call Connected LED momentarily flashes during tone or pulse dialing. In the event that the line is busy or there is a ring-no-answer, the unit can be programmed to call additional phone numbers. The phone then cycles through up to 5 pre-programmed emergency numbers until the call is answered. When the call is answered, handsfree communication to emergency personnel is established. The digital voice announcer will automatically play to identify the location of the emergency call. The * key will stop the announcement, send the I.D. number (if programmed) and light the "Call Connected" LED. Alternatively, the phone can be programmed to automatically light the "Call Connected" LED after the announcement has played a programmed number of times. The distant party will know the location of the emergency call by either the voice announcement or by decoding the Touch Tone I.D. number. Pressing the * key again will send the I.D. number and play the message again. Once the * key has been pressed, the # key can be used to force the phone to hang-up.

B. Central Station Operation

After the "HELP" button on the **E-1600A-BLT-EWP** phone has been pressed, the phone will begin to dial. If a voice number is programmed in memory locations **#00-#04**, these numbers will be dialed first. Upon detecting a busy signal or after a preprogrammed ring delay, the phone will hang-up and dial the central station phone number stored in memory location **#05**. When the central station receiver answers, it will send a handshake tone to the phone. Upon detecting the handshake tone, the **E-1600A-BLT-EWP** phone will begin uploading the information stored in memory location **#20**.

Once the **E-1600A-BLT-EWP** emergency phone has sent the information stored in memory location **#20**, it waits for a "kiss-off" tone from the central station. When the "kiss-off" tone is received, the emergency phone turns on the call connected LED and goes into the "two-way talk mode" or hangs up and dials position **#06** if programmed. **Note:** *The central station should have a "talk-over" feature that will allow a two way conversation at this time. If your receiver does not support "talk-over", a voice phone number should be programmed into position #06.* If the central station answers the call and does not send a "kiss-off", the next number will be dialed (if programmed). In either single number or multi-number programming, the phone will keep dialing until a call is completed.

Options

1600A Series ADA* Compliant Emergency Phones with Built-In Digital Voice Announcer



The **1600A Series** ADA Compliant Emergency Phones are designed to provide quick and reliable handsfree communication over the public switched telephone network. All **1600A Series** phones meet ADA requirements for elevator/emergency telephones, and can be programmed from any Touch Tone phone. The phones can dial up to 5 programmable emergency numbers, as well as 2 central station numbers. In addition, the **E-1600-20A** features an "Info" button that will dial up to 3 non-emergency numbers.

The **1600A Series** phones can be programmed to automatically deliver a digital announcement to identify the location of the emergency call and then initiate the call connected LED light. Alternatively, a DTMF Touch Tone code may also be delivered. All

programming parameters, including phone numbers and location numbers, are stored in non-volatile E² memory. All units are phone line powered, requiring no batteries or external power and are compatible with common Central Station Monitoring equipment.

For outdoor or harsh environments, select **1600A Series** phones are available with Enhanced Weather Protection (**EWP**). EWP products feature rubber gaskets and boots, hand soldered silicon sealed connections, gel filled tip and ring connectors, as well as urethane potted circuit boards with weather sealed, field-adjustable trim pots and DIP switches for easy on-site programming.

 Need More Information on the 1600A Series?
Call (715) 386-4345 and select 215.

PB-100 Polling and Diagnostics Kit

The **PB-100** system provides centralized polling and diagnostics of all **Viking 1600** and **1600A** series emergency phones through a standard Windows 9x/NT P.C. In addition, any device or human capable of returning DTMF Touch Tones can be automatically polled.

Up to 500 individual phones can be polled, at timed intervals, for the diagnosis of proper programming and operation. The included software provides storage of complete contact/location records associated with the phones ID. Devices that are polled successfully are stored in a "success" log while devices that returned any kind of error are stored in a "failure" log.



 Need More Information on the PB-100?
Call (715) 386-4345 and select 860.

Product Support Line...715.386.8666

Fax Back Line...715.386.4345

Due to the dynamic nature of the product design, the information contained in this document is subject to change without notice. Viking Electronics, and its affiliates and/or subsidiaries assume no responsibility for errors and omissions contained in this information. Revisions of this document or new editions of it may be issued to incorporate such changes.